

# DETACHABLE JOINT FOR UPVC PIPE (TYPE B)

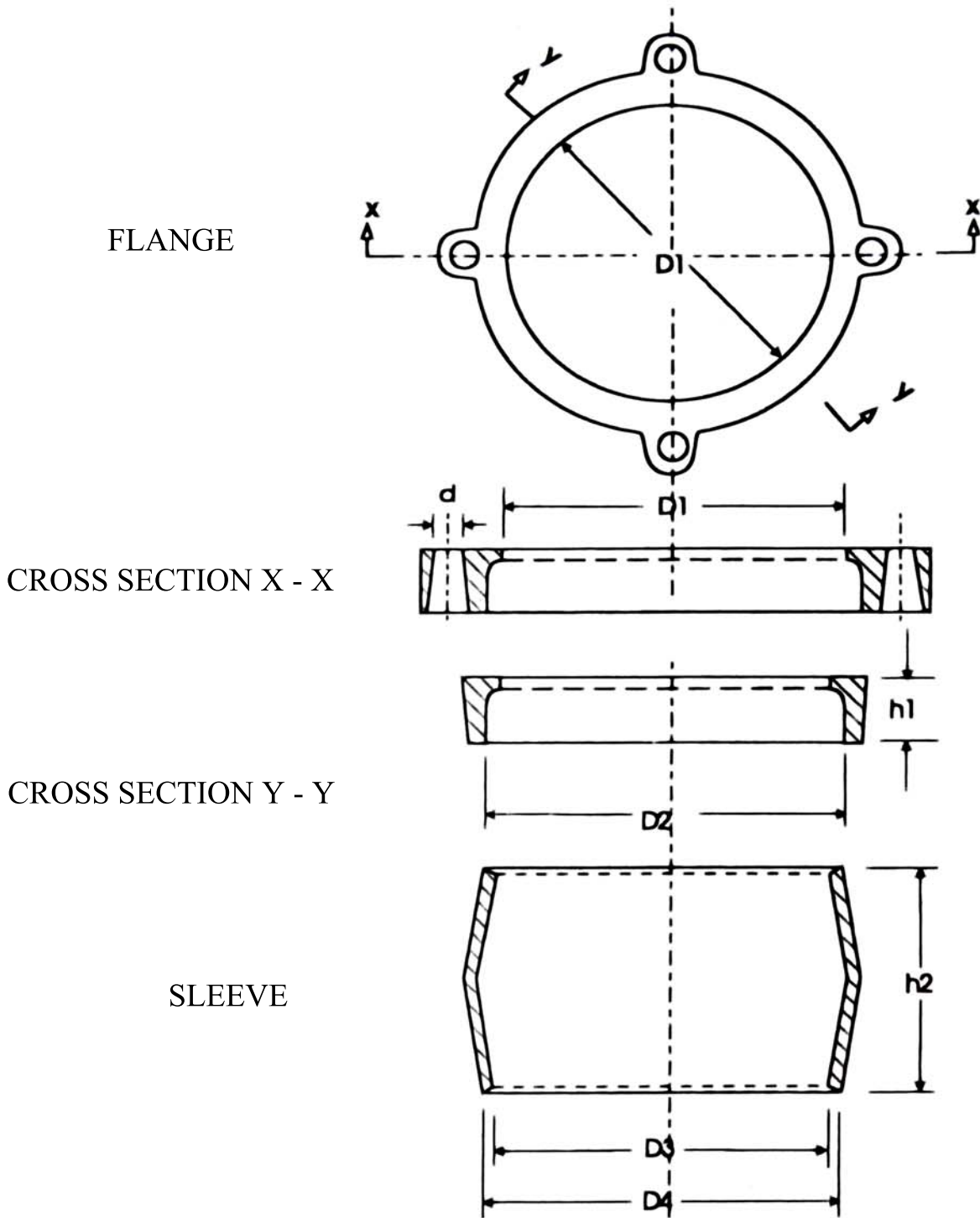

PIPE		FLANGE				SLEEVE			BOLT	
SIZE	O.D	D1	D2	d	h1	D3	D4	h2	dia. of bolt	no. of bolt
PVC 2'	60.3	67	88	14	25	67	80	100	12	3
3'	88.9	93	113	14	25	93	105	100	12	3
4'	114.5	121	141	14	26	121	134	110	12	3
6'	168.5	172	194	14	30	172	189	126	12	4
8'	219.4	226	246	20	31	226	224	140	16	4
10'	273.4	280	303	20	35	280	297	150	16	4
12'	324.3	328	354	20	40	328	344	160	16	5

AC 2'	69.1	80	101	14	25	80	92	100	12	3
3'	95.6	103	123	14	25	103	116	100	12	3
4'	121.9	128	148	14	26	128	140	110	12	3
6'	177.3	182	206	14	30	182	196	126	12	4
8'	232.2	238	259	20	31	238	254	140	16	4
10'	286	292	315	20	35	292	307	150	16	4
12'	345.4	350	376	20	40	350	366	160	16	5
12'B	333.8	343	369	20	40	343	359	160	16	5

DI. 4'	118	121	141	14	26	121	134	110	12	3
6'	170	172	194	14	30	172	189	126	12	4
8'	222	226	246	20	31	226	244	140	16	4
10'	274	280	303	20	35	280	297	150	16	4
12'	326	328	354	20	40	328	344	160	16	5
14'	378									
16'	429									
18'	480									
20'	532									

POLY	110	115	138	14	26	115	127	108	12	3
125	125									
160	160	164	184	14	30	164	178	126	12	4
180	180									
200	200									
225	225	229	249	20	31	229	248	140	16	4
250	250	255	278	20	35	255	270	150	16	4
280	280	284	308	20	35	285	302	150	16	4
315	315	320	346	20	40	320	336	160	16	5
355	355									
450	450	455	489	20	50	457	473	160	16	6
500	500	505	539	20	50	507	523	160	16	6